

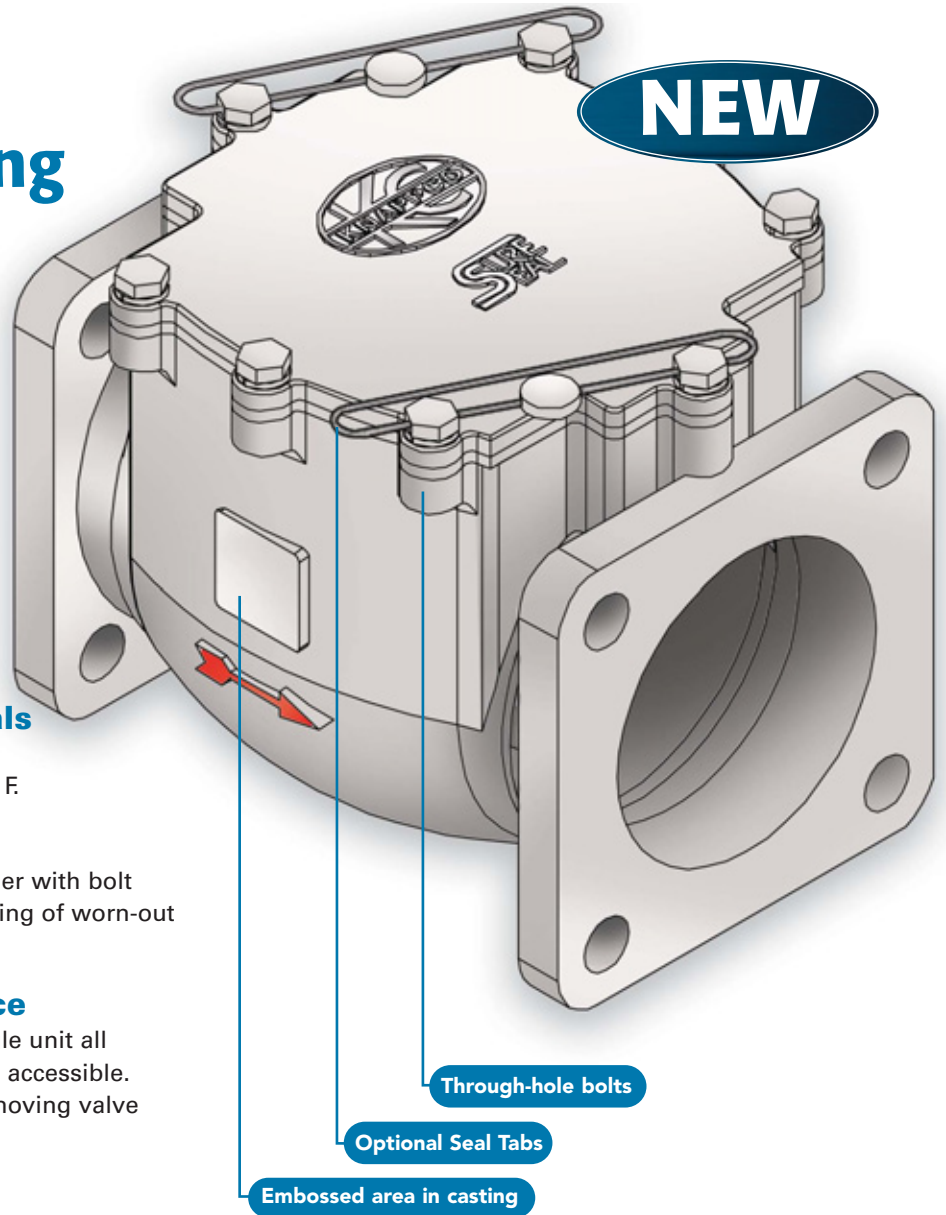

Sure Seal 3" Aluminum Swing Check Valve

Sure Seal 3" Aluminum Swing Check Valve



More Air Flow

A high flow valve means less pressure drop and faster unloading rates.

Less Heat Build Up

Due to the spherical design of the Sure Seal 3" Aluminum Swing Check Valve less turbulence is created in the air stream, reduces back pressure, provides smoother air flow reducing heat build up and wear and tear on the blower.

Molded Silicone Poppet Seals

Designed to withstand high temperature dry bulk environments. Seal rated to 450° F.

Through-Hole Bolts

Removal of Valve Cap bolts are made easier with bolt through-holes. Through-holes allow servicing of worn-out bolts without destroying the casting.

Easier to Rebuild and Service

Since the poppet and top lift out as a single unit all serviceable parts are easily and efficiently accessible. Field maintenance is possible without removing valve from air line.

Optional Seal Tabs

To ensure load integrity.

Embossed Casting Area

Provides an area to personalize each valve.

Light Weight

Light weight aluminum, heavy duty construction.

Reliable

Each valve is manufactured and tested within rigorous ISO 9001 standards and processes.

Ordering Specifications

| Part Number | Description |
|-------------|--|
| VC3012 | 3" Flanged with Silicone poppet |
| VC3022 | 3" Flanged with Silicone poppet, spring loaded |

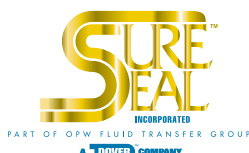

PHONE: (573) 438-5000 • Fax: (573) 438-4853
1172 State Highway 0 • Mineral Point, MO 63660 • www.suresealinc.com