

# SureClean

IN-LINE AIR FILTRATION

## The Best Air Filtration System for Pneumatic Tank Trailers Available

*Can we build one for you?*

**SureClean**  
IN-LINE AIR FILTRATION



Filter is interchangeable with PneuClean and ZC units

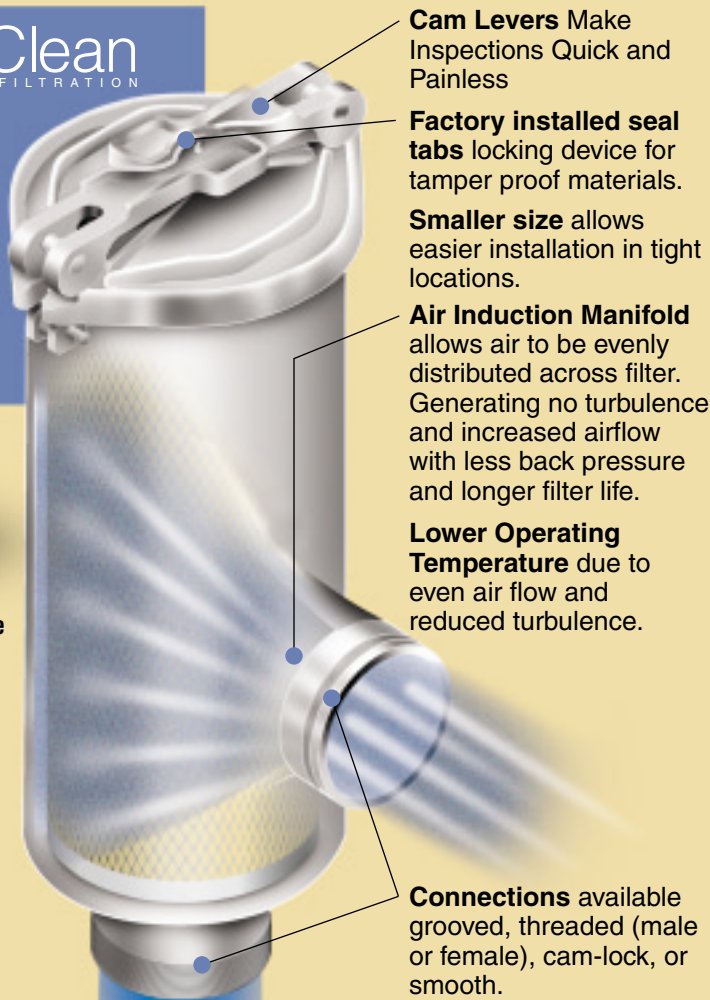

SureClean uses a system of locking cam levers and a spring loaded plate which applies even pressure to the filter top plate. Tension is factory set and never needs adjustment.

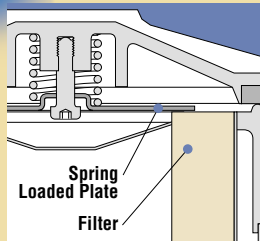

## The Competition

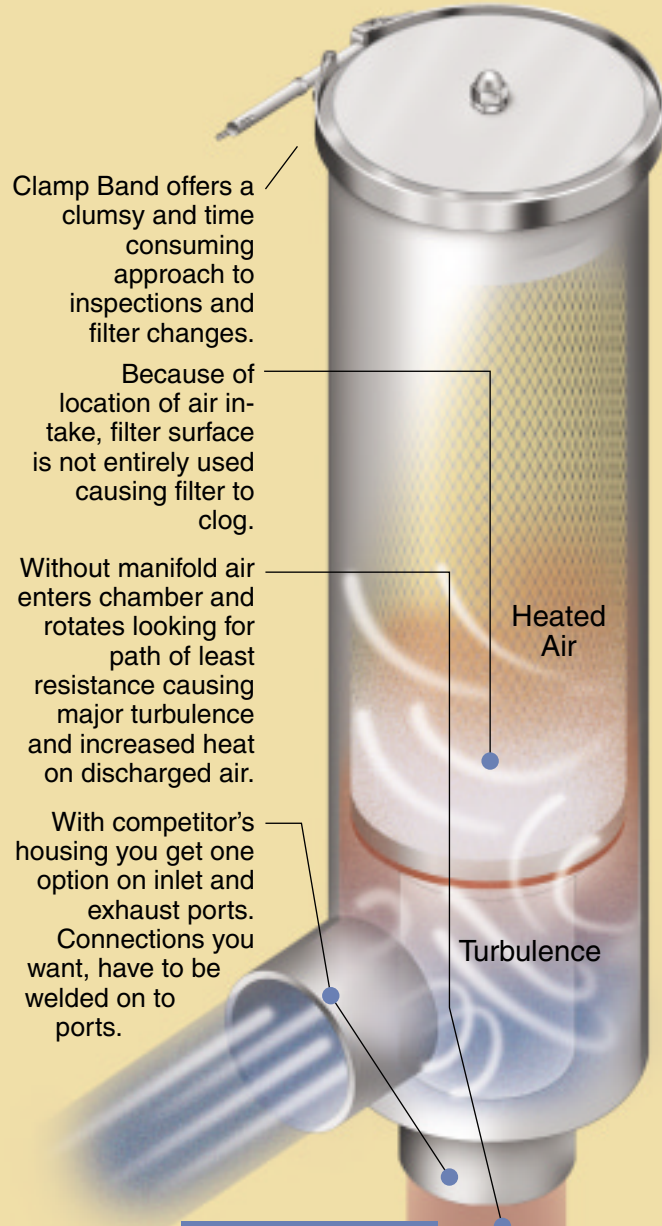

The Competition uses a bolt to put pressure on the filter to hold it in place. Resulting in constantly adjusting the bolt to put correct pressure on filter. Also damaging the top plate of the filter element causing premature failure and replacement.

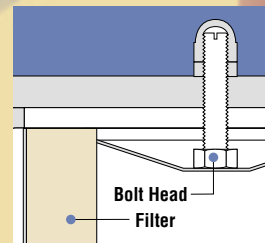

For More Information on Sure Seal Products or the Name of Your Nearest Dealer Call 1-800-382-1604 or Visit us on the Web at [www.suresealinc.com](http://www.suresealinc.com)

©2001 Sure Seal, Incorporated • Patent Pending



# SPECIFICATIONS FOR SureClean

IN-LINE AIR FILTRATION

Item	Part
1	Body
2	Filter
3	Inlet
4	Outlet
5	Lid
6	Ring
7	Plate
8	Cam
9	Eyebolt
10	Cotter Pin
11	Clevis Pin 5/16" x 1.75
12	Clevis Pin 5/16" x 2.00
13	Clevis Pin 5/16" x 2.25
14	Bolt
15	Bottom Gasket
16	Top Gasket
17	Spring
18	Nut
19	Jam Nut

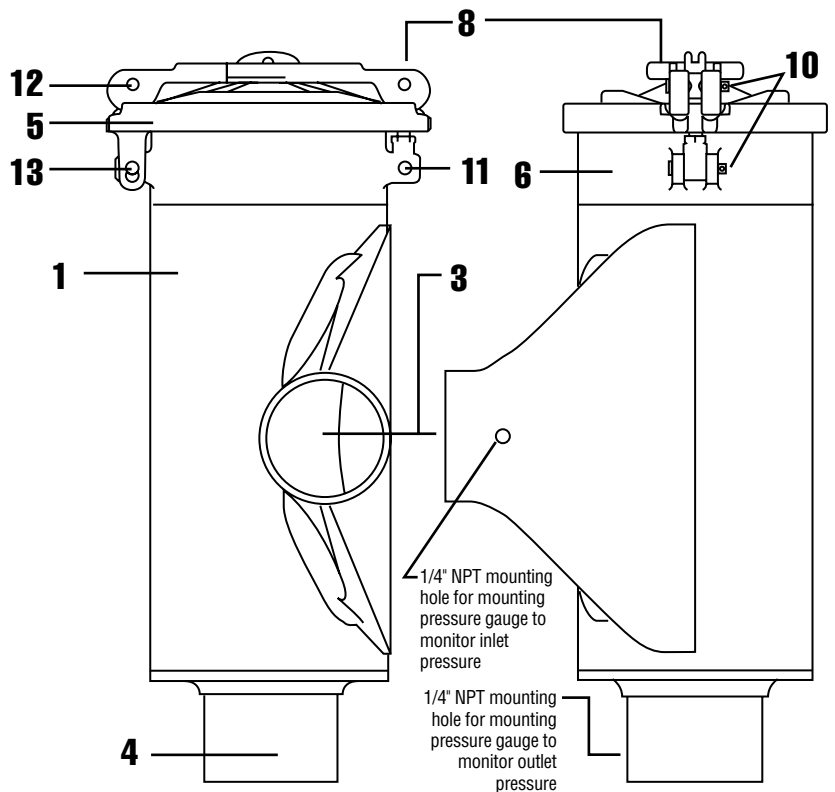

## Inlet and Outlet Styles

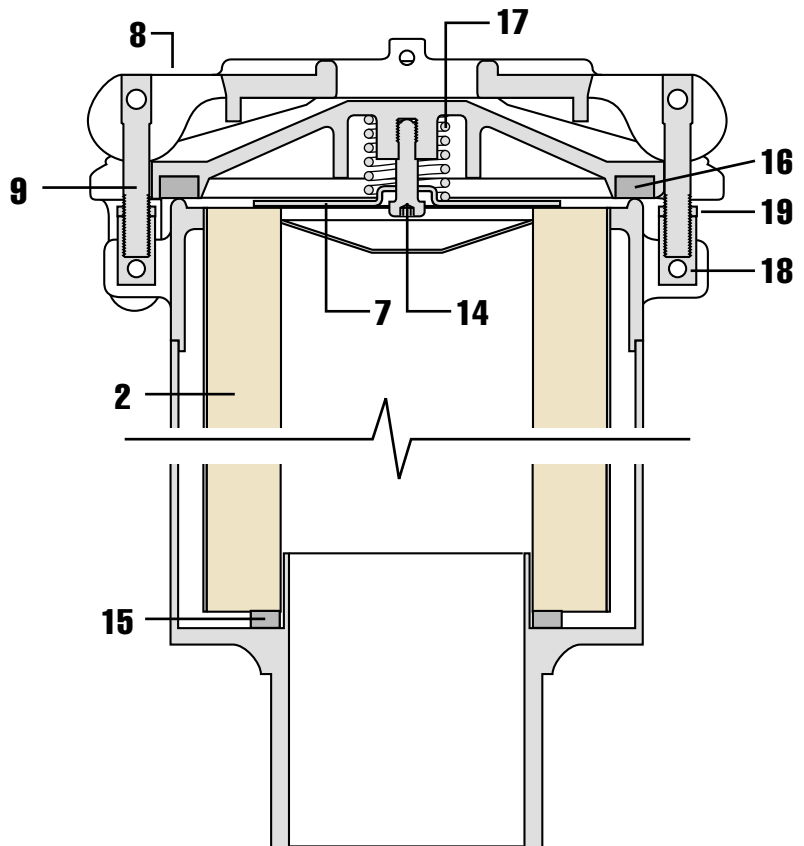
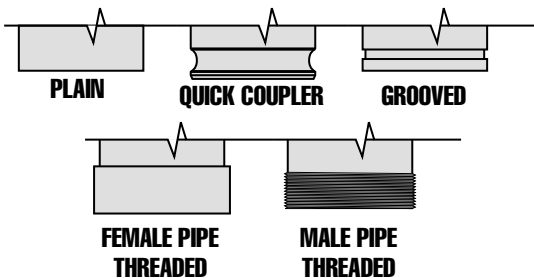

## Pneumatic Conveying System Filter:



FDA approvable Medium with 99% maximum efficiency for removing all particles at (1) one micron and larger

Maximum operating temperature 400 degrees F

Will handle air volumes at 1000 CFM with .05 PSI back pressure

Filter has 91 pleats (1" pleats) with 23.75 sq. ft. of polyester felt media

For More Information on Sure Seal Products or the Name of Your Nearest Dealer Call 1-800-382-1604 or Visit us on the Web at [www.suresealinc.com](http://www.suresealinc.com)



Making a big difference to your bottom line

©2001 Sure Seal, Incorporated • Patent Pending