

Advantage

Sure Seal and You!



The best just got better

Introducing Oil Impregnated Bronze Bushings

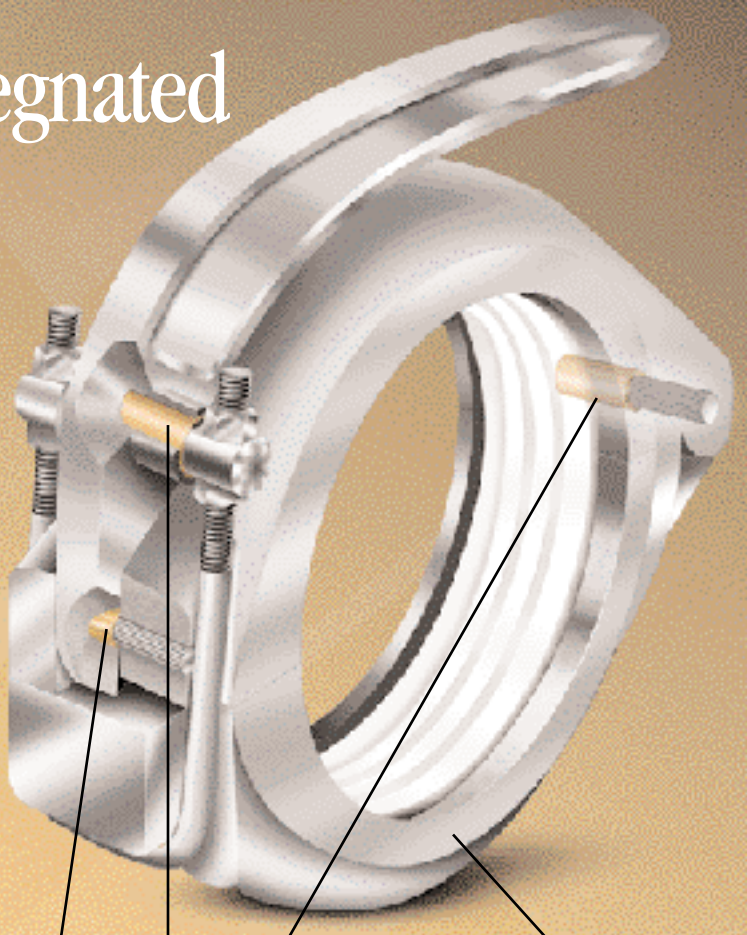

Oil Impregnated Bronze Bushings

Completely made from Stainless steel and Aluminum for superior corrosion resistance and light weight.

THE CLEAN SEAL SYS-

INDUSTRY'S PREVIOUS DESIGN GASKET

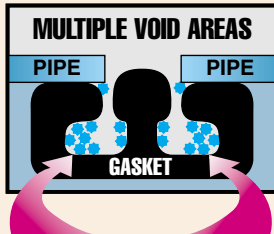

Void areas in gasket create hiding spots for contamination. This makes cleaning hard to reach spots costly.

THE CLEAN SEAL DESIGN GASKET

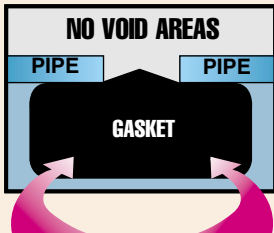

With no void areas in gasket there is no place for contamination to hide. A quick disassembly and visual inspection is all that is necessary.

Don't ever let down time or contamination get the best of you.

Sure Seal introduces an exciting new improvement to our superior line of pipe couplers for the Dry Bulk Industry. We've developed a solution for your most common problem - coupler freeze up. The solution and your advantage is the newly designed Sure Seal pipe coupler with oil impregnated bronze bushings at critical hinge points.

The industry has spoken and once again Sure Seal has responded, just another reason why we're the most innovative company in the industry.



Sure Seal Inc. • Rt. 2, Box 2242, Mineral Point, MO 63660

1-800-382-1604 • (573) 438-5000 • Fax: (573) 438-4853

Patent Pending ©1996 Sure Seal Inc.

634GG GROOVED PIPE TO GROOVED PIPE

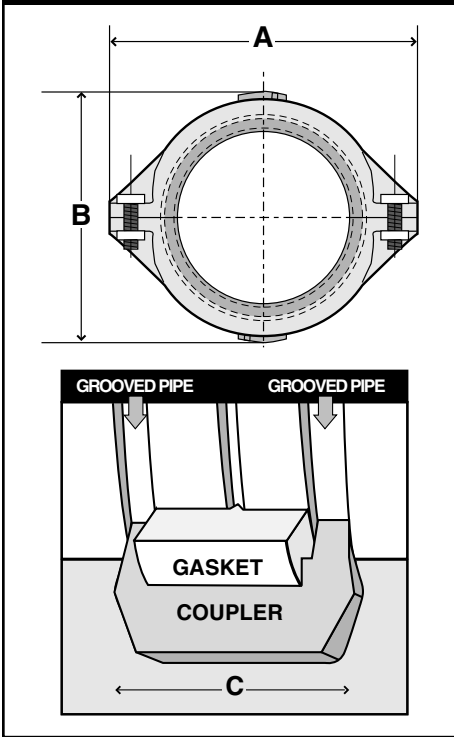

635PP PLAIN PIPE TO PLAIN PIPE

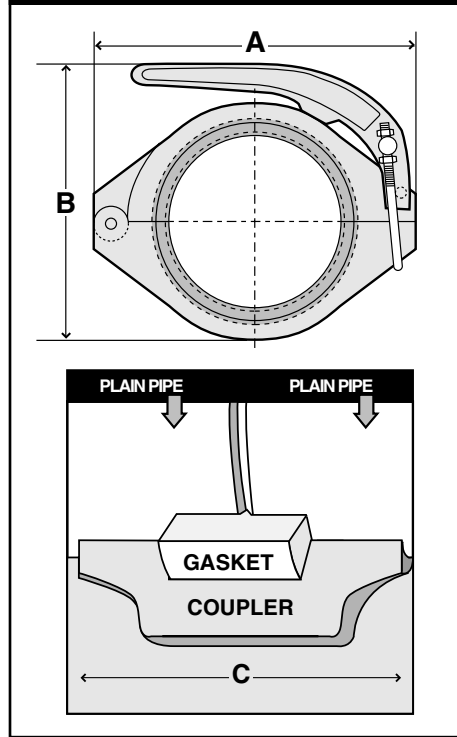

635GP GROOVED PIPE TO PLAIN PIPE

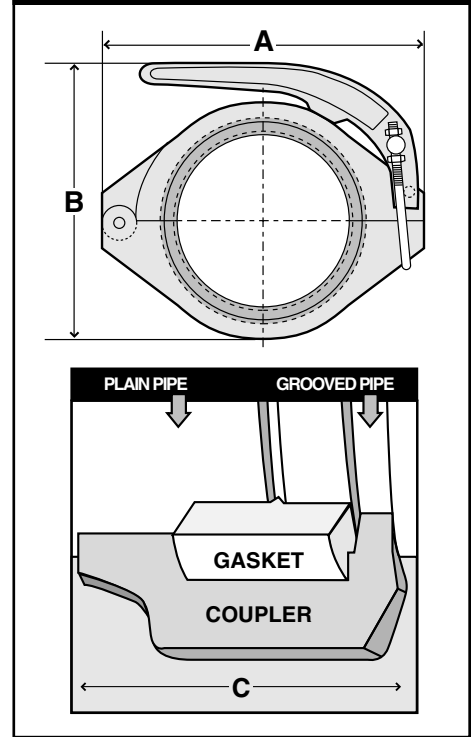

The aluminum quick couplers are furnished in different styles. The grooved pipe to grooved pipe coupler part numbers are 632GG, 634GG, 635GG, and 639GG. These couplers are superior to other couplers on the market today for the transportation industry. They are completely manufactured out of 713 aluminum and stainless steel for light weight and have SAE 841 oil impregnated bronze bushings in all pivot points. The couplers are corrosion resistant, they are adjustable, and are also easy to operate.

The part number 635GP is for grooved pipes or hopper tees to non grooved pipes. Most hopper tees have a groove on both ends, but most intermediate pipes do not

have a groove on both ends. The part number 635PP is for pipes or hopper tees without grooves on either pipe. These two couplings can be used in applications to replace the band style clamps. Most band clamps are rated at 10 psi, where the Sure Seal couplers are rated at 50 psi.

CLEAN SEAL GASKETS are easy to install and replace. White gaskets are special formulated for dry bulk applications where F.D.A. approval is required. Black gaskets are specially formulated for petroleum products, while red gaskets are for high temp applications up to 400 degrees Fahrenheit.

632GG/635GG/637GG/639GG GROOVED PIPE TO GROOVED PIPE

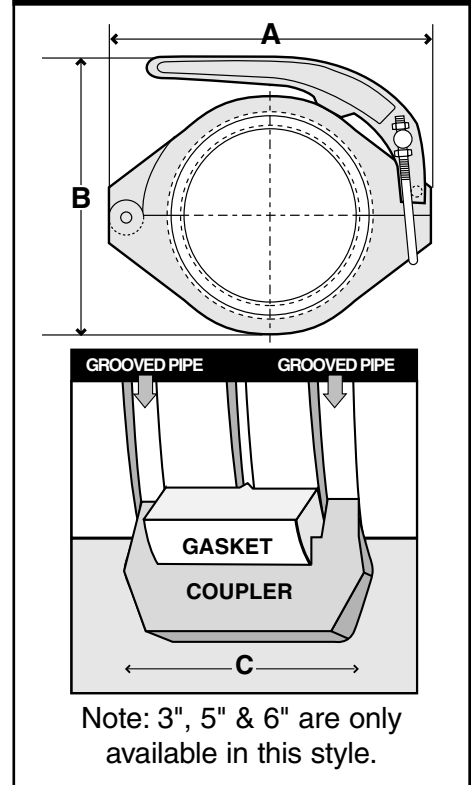

Description, Part Numbers & Weight				Dimensions			
Pipe or Tubing		Material	Part No.	Wt. Lbs	A	B	C
Nom. Size	O.D.						
3	3.500	Aluminum Clamp & SS Hardware	632GG	1.75	5.150	5.190	1.75
4	4.500	Aluminum Clamp & Bolts	634GG	2.4	7.900	6.000	2.000
4	4.500	Aluminum Clamp & SS Hardware	635GG	2.6	7.900	7.300	2.000
4	4.500	Aluminum Clamp & SS Hardware	635GP	2.8	7.900	7.300	3.000
4	4.500	Aluminum Clamp & SS Hardware	635PP	2.8	7.900	7.300	3.000
5	5.500	Aluminum Clamp & SS Hardware	637GG	3.5	9.200	8.100	2.000
6	6.625	Aluminum Clamp & SS Hardware	639GG	4.0	10.30	9.200	2.00

